

D12-16-20-25

D32-40-50-63-80-100

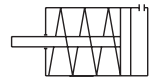
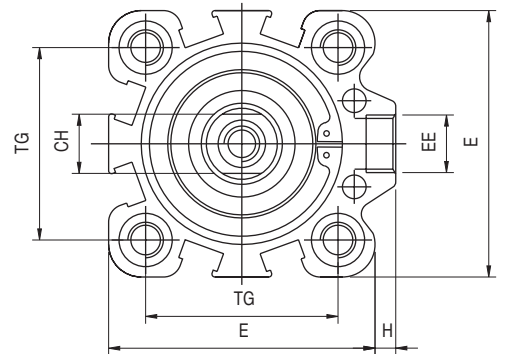
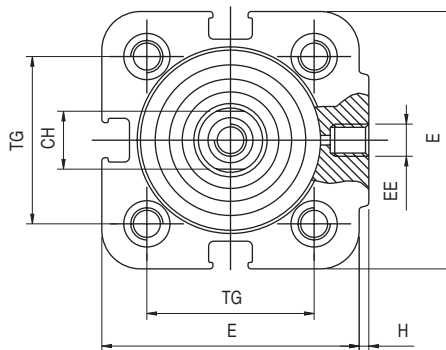
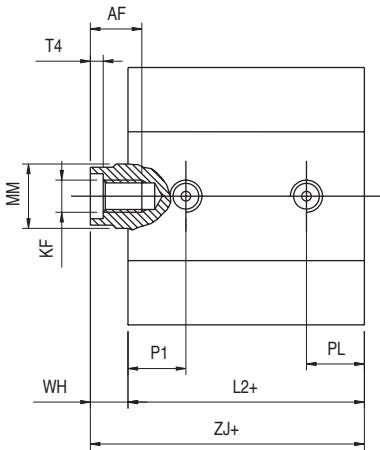

+= aggiungere la corsa + = add stroke
 * = per corsa corta filetto passante * = Through threads only on small strokes

BB

SEMPLICE EFFETTO MAGNETICO - SINGLE-ACTING MAGNETIC

Ø mm.	AF	RT	BG*	D2Ø	E	EE	FBØ	H	KF	L2+	L3	MMØ	P1	PL	T4	TG	WH	ZJ+	CH
12	6	M4	12.5	5.5	29	M5	3.3	1	M3	28	3.5	6	7.5	7.5	1.5	18	6	34	5
16	8	M4	14.5	5.5	29	M5	3.3	1	M4	30.5	3.5	8	8.5	8.5	2	18	6	36.5	7
20	8	M5	16.5	7.2	36	M5	4.2	1.5	M5	31.5	4.5	10	9	9	2	22	6	37.5	9
25	8	M5	16.5	7.2	40	M5	4.2	1.5	M5	31.5	4.5	10	9	9	2	26	6	37.5	9
32	10	M6	21.7	8.5	45	G1/8	5	3.5	M6	32	5.7	12	10	10	2.8	32.5	7	39	10
40	10	M6	21.7	8.5	52	G1/8	5	5	M6	38.5	5.7	12	11	11	2.8	38	7.2	45.7	10
50	12	M8	22.8	10	63.5	G1/8	6.8	7	M8	39	6.8	16	11	11	3.5	46.5	8.5	47.5	13
63	12	M8	22.8	10	77	G1/8	6.8	7	M8	46	6.8	16	11.5	11.5	3.5	56.5	8	54	13
80	16	M10	25	13	92	G1/8	8.5	10	M10	54	9	20	14	14	4.5	72	11	65	17
100	20	M10	25	13	113	G1/4	8.5	13	M12	65	9	25	17.5	17.5	6	89	12	77	22