

512

PRESA PROLUNGATA CON ATTACCO MASCHIO - EXTENDED MALE SOCKET

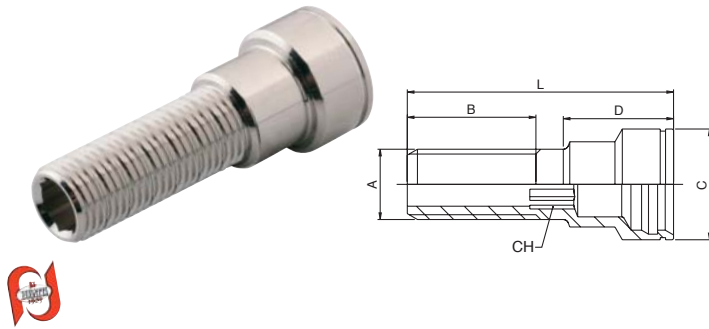

| A | B | C | D | L | CH | Conf. Pack. |
|-----|----|----|----|-----|----|-------------|
| 1/8 | 27 | 21 | 21 | 50 | 5 | 10 |
| 1/8 | 60 | 21 | 21 | 100 | 5 | 10 |
| 1/8 | 60 | 21 | 21 | 150 | 5 | 10 |
| 1/8 | 60 | 21 | 21 | 200 | 5 | 10 |
| 1/4 | 27 | 21 | 20 | 50 | 8 | 10 |
| 1/4 | 60 | 21 | 20 | 100 | 8 | 10 |
| 1/4 | 60 | 21 | 20 | 150 | 8 | 10 |
| 1/4 | 60 | 21 | 20 | 200 | 8 | 10 |
| 3/8 | 35 | 21 | 11 | 50 | 10 | 10 |
| 3/8 | 60 | 21 | 11 | 100 | 10 | 10 |
| 3/8 | 60 | 21 | 11 | 150 | 10 | 10 |
| 3/8 | 60 | 21 | 11 | 200 | 10 | 10 |